

## 155Mbps 1x9 SC Duplex Optical Transceiver Module for Fast Ethernet, ATM, SONET/OC-3, SDH/STM-1



### Features :

- Full Compliance with the Optical Performance Requirements of the ATM 100Mbps and 100 Base-FX Version of IEEE 802.3u.
- Industry Standard 1x9 Footprint and Duplex SC Connector Interface.
- Single 5V (OPT-155B1xxxxx) or 3.3V (OPT-155B2xxxxx) Power Supply.
- PECL Differential Inputs and Outputs.
- PECL Receiver Signal Detect Indicator.
- RoHS Compliance.
- Wave Solder and Aqueous Wash Process Compatible.

### Description :

The OPT-155Bxxxxxx series are 1x9 optical transceiver modules designed expressly for high-speed communication applications that require rates of up to 155Mbps. They are all compliant with the SONET/SDH standards.

The OPT-155Bxxxxxx transceivers are supplied in industry standard 1x9 SIP package style with duplex SC connector.

The OPT-155Bxxxxxx also includes a Signal-Detect circuit that provides PECL logic output state.

The OPT-155Bxxxxxx transceivers can meet Class-1 eye safety products and effective distance depending on ITU-T G.957 standard or power penalty.

The transmitter sections utilize 1310nm Edge Emitting InGaAsP Laser Diode. This Laser Diode is packaged in the optical subassembly portion of the transmitter section. A custom silicon IC that converts differential PECL logical signals into an analog LD driving current drives it.

The receiver sections utilize InGaAs PIN photodiodes coupled into a custom silicon trans-impedance preamplifier IC. These are packaged in the optical subassembly portion of receiver.

These PIN / Preamplifier combinations are coupled into a custom quantizer IC which provides the final pulse shaping for the logic output and the Signal Detect function. The data output is differential. The signal detect output is single-ended.

### Application :

- Single-mode Fiber Backbone Links.
- Fast Ethernet and ATM Compatible.
- Single-mode Fiber Media Converter.

**Absolute Maximum Ratings**

Parameter	Symbol	Min.	Typ.	Max.	Unit	Note
Storage Temperature	T <sub>s</sub>	-40		85	°C	
Lead Soldering Temperature	T <sub>SOLD</sub>			260	°C	
Lead Soldering Time	t <sub>SOLD</sub>			10	Sec.	
Supply Voltage	V <sub>CC</sub>	0		6	V	

**Recommended Operating Conditions**

Parameter	Symbol	Min.	Typ.	Max.	Unit	Note
Data Rate		100	155.52	200	Mbps	
Ambient Operating Temperature	T <sub>A</sub>	0		70	°C	1
Supply Voltage						
OPT-155B1xxxxx	V <sub>CC</sub>	4.75	5	5.25	V	
OPT-155B2xxxxx		3.15	3.3	3.45		

Note: See "Order Information" for detail

**Electrical Characteristics**

Parameter	Symbol	Min.	Typ.	Max.	Unit	Note
<b>Transmitter</b>						
Transmitter Data Input Voltage-Low	V <sub>IL-VCC</sub>	-1.81		-1.48	V	
Transmitter Data Input Voltage-High	V <sub>IH-VCC</sub>	-1.16		-0.88	V	
<b>Receiver</b>						
Data Output Voltage-Low	V <sub>OL-VCC</sub>	-1.95		-1.62	V	
Data Output Voltage-High	V <sub>OH-VCC</sub>	-1.045		-0.74	V	
SD Output Voltage-Low	V <sub>SDL-VCC</sub>	-1.95		-1.62	V	
SD Output Voltage-High	V <sub>SDH-VCC</sub>	-1.045		-0.74	V	

**Optical Characteristics**

 ( Data Rate = 155.52Mbps, PRBS=2<sup>23</sup>-1, NRZ, 9/125um SMF )

Parameter	Symbol	Min.	Typ.	Max.	Unit	Note
<b>Transmitter</b>						
Supply Current	I <sub>CC</sub>			165	mA	
Mean Launch Power	P <sub>O</sub>	-20		-15	dBm	OPT-155BxHxxxx
		-15		-8		OPT-155BxJxxxx
		-8		-5		OPT-155BxLxxxx
		-5		0		OPT-155BxMxxxx
Optical Extinction Ratio	E.R.	8.2			dB	OPT-155BxHxxxx
		8.2				OPT-155BxJxxxx
		8.2				OPT-155BxLxxxx
		10				OPT-155BxMxxxx
Center Wavelength	λ <sub>c</sub>	1270	1310	1360	nm	
Spectral Width (RMS)	σ			7.7	nm	OPT-155BxHxxxx
				7.7		OPT-155BxJxxxx
				7.7		OPT-155BxLxxxx
				3		OPT-155BxMxxxx
Output Eye Diagram	Compliant with ITU-T recommendation G.957					
<b>Receiver</b>						
Supply Current	I <sub>CC</sub>			145	mA	
Sensitivity	P <sub>IN</sub>			-31	dBm	OPT-155BxHxxxx
				-31		OPT-155BxJxxxx
				-31		OPT-155BxLxxxx
				-34		OPT-155BxMxxxx
Overload	P <sub>SAT</sub>	-8			dBm	
Signal Detect-Asserted	P <sub>A</sub>			-31	dBm	OPT-155BxHxxxx

				-31		OPT-155BxJxxxx
				-31		OPT-155BxLxxxx
				-34		OPT-155BxMxxxx
Signal Detect-DeAsserted	$P_D$	-45			dBm	
Signal Detect-Hysteresis	$P_A - P_D$	0.5			dB	

Notes: The sensitivity is provided at a BER of  $1 \times 10^{-10}$  or better with an input signal consisting of 155Mbps,  $2^{23}-1$  PRBS and E.R.=9dB.

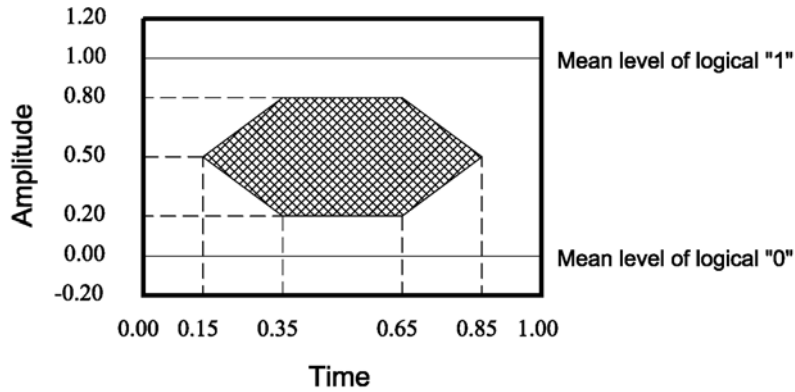

Optical Pulse Mask with Bessel Filter Specified in ITU-T G.957  
**Mask of the eye diagram for the optical transmit signal**

## Pin Definition

PIN	Symbol	Functional description
1	GND	Receiver Signal Ground
2	RD (+)	Receiver Data Out Non-inverted (LVPECL or PECL)
3	RD (-)	Receiver Data Out Inverted (LVPECL or PECL)
4	SD	Receiver Signal Detect (LVPECL or PECL)
5	VccR	Receiver Power Supply
6	VccT	Transmitter Power Supply
7	TD (-)	Transmitter Data In Inverted (LVPECL or PECL)
8	TD (+)	Transmitter Data In Non-inverted (LVPECL or PECL)
9	GND	Transmitter Signal Ground

## Pin Descriptions

### Pin 1 Receiver Signal Ground, GND

Directly connect these pins to the ground plane.

### Pin 2 Receiver Data Out Non-inverted (LVPECL), RD (+)

PECL logic family. Output external biased and internal DC coupled.

### Pin 3 Receiver Data Out Inverted (LVPECL), RD (-)

PECL logic family. Output external biased and internal DC coupled.

### Pin 4 Receiver Signal Detect (LVPECL), SD

PECL logic family. Normal Operation: Logic "1" Output; Fault Condition: Logic "0" Output.

### Pin 5 Receiver Power Supply, VccR

Provide +3.3V dc power supply.

### Pin 6 Transmitter Power Supply, VccT

Provide +3.3V dc power supply.

### Pin 7 Transmitter Data In Inverted (LVPECL), TD (-)

Pin 7 Transmitter Data Input Inverted (LVPECL), TD (-).

### Pin 8 Transmitter Data In Non-inverted (LVPECL), TD (+)

Pin 8 Transmitter Data Input Non-inverted (LVPECL), TD (+).

### Pin 9 Transmitter Signal Ground, GND

Directly connect these pins to the ground plane.

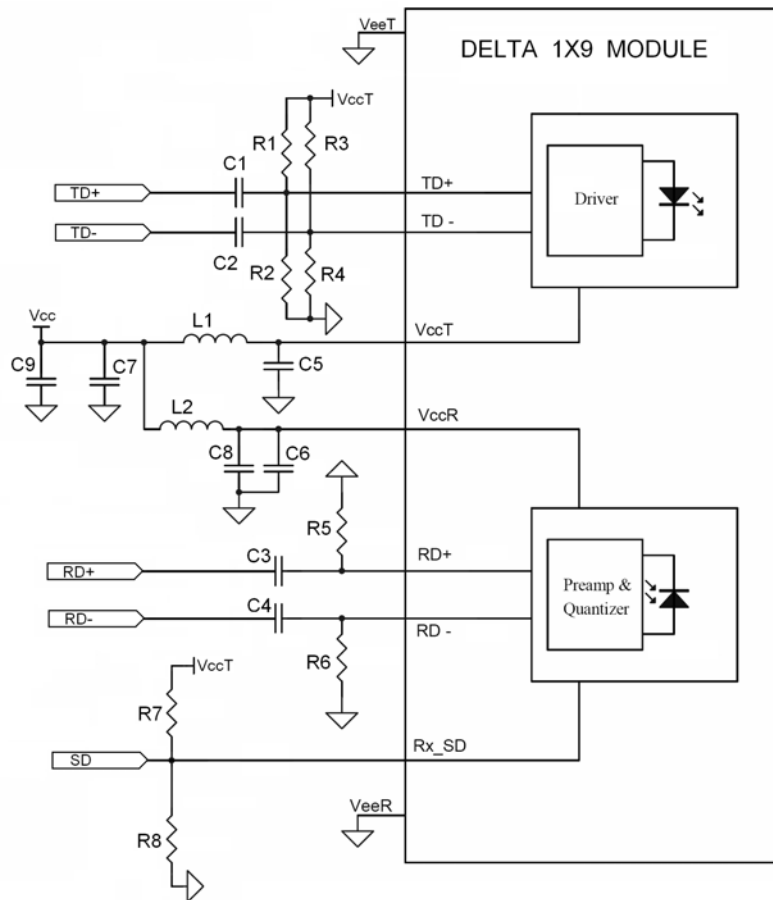
**Recommended Circuit Schematic**

R1=R3=82 ohm (3.3V),68 ohm(5V)  
 R2=R4=130 ohm (3.3V),191 ohm (5V)  
 R5=R6=150 ohm (3.3V),270 ohm (5V)  
 R7=130 ohm (3.3V PECL),82 ohm(5V),NC (TTL)  
 R8=82 ohm (3.3V PECL),130 ohm(5V),NC (TTL)  
 C1=C2=C3=C4=C5=C6=C7=100 nF  
 C8=C9=10uF  
 L1=L2=1uH

Package Outline Drawing

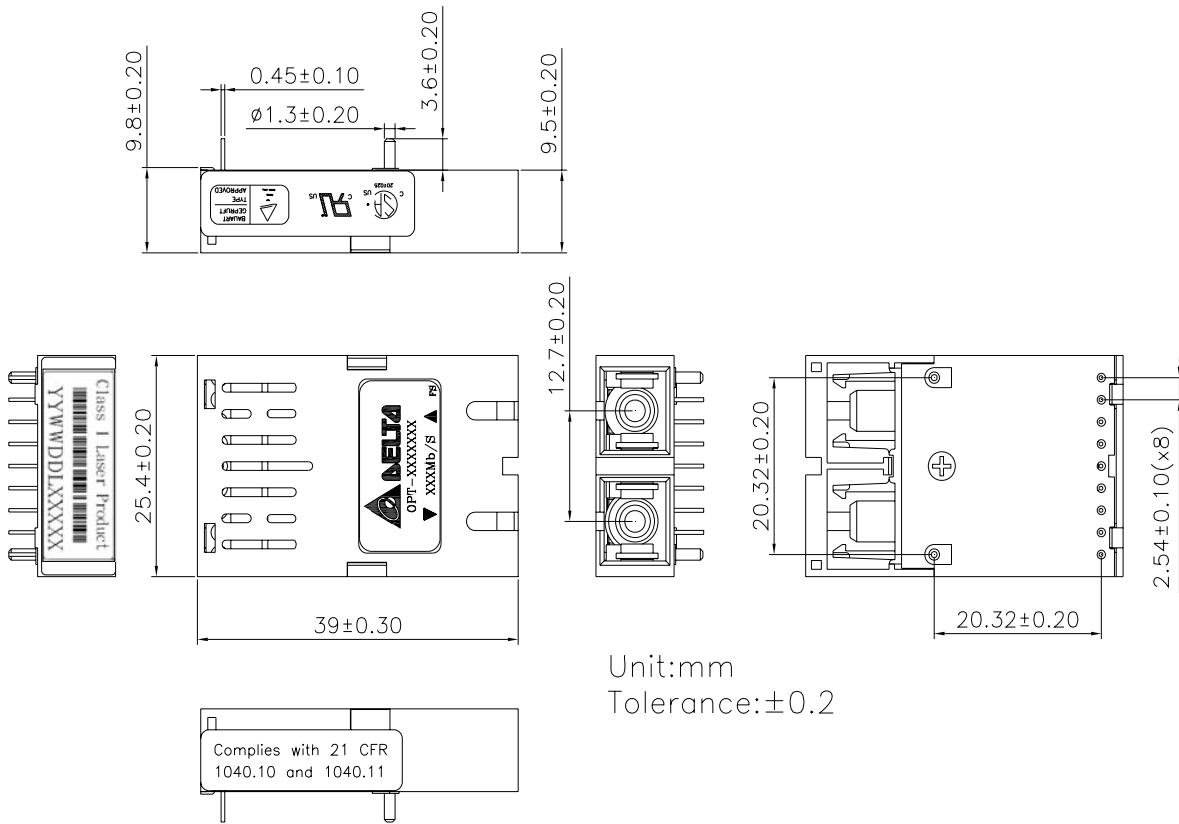

Unit:mm  
Tolerance:±0.2

## Regulatory Compliance

Feature	Reference	Performance
Electromagnetic Interference (EMI)	FCC Class B EN 55022 Class B (CISPR 22A)	(1) Satisfied with electrical characteristics of product spec.  (2) No physical damage
Radio Frequency Electromagnetic Field	EN 61000-4-3 IEC 1000-4-3	
Electrostatic Discharge to the Duplex LC Receptacle	EN 61000-4-2 IEC 1000-4-2 IEC 801.2	
Electrostatic Discharge to the Electrical Pins	MIL-STD-883E Method 3015.7	
Eye Safety	US FDA CDRH AEL Class 1 EN 60950: 2000 EN 60825-1: 1994+A11+A2 EN 60825-2: 2000	CDRH File # 0321539-00 TUV Certificate No. R50032471
Component Recognition	Underwriters Laboratories and Canadian Standards Association Joint Component Recognition for Information Technology Equipment Including Electrical Business Equipment	UL File # E239394

## Order information

### OPT- 155BX<sub>1</sub>X<sub>2</sub>X<sub>3</sub>X<sub>4</sub>X<sub>5</sub>X<sub>6</sub>

**X<sub>1</sub> Power Supply Voltage and SD Level**

1: 5.0V, PECL SD Level  
2: 3.3V, PECL SD Level

**X<sub>2</sub> Distance**

J: 15km  
M: 40km

**X<sub>3</sub> Data Coupling**

1: 1x9 SC DC/DC

**X<sub>4</sub> RoHS**

**Blank:** Non-RoHS Compliant  
**R:** RoHS Compliant

**X<sub>5</sub> Performance**

**Blank:** Old Design  
**A:** New Design

**X<sub>6</sub> Temperature**

**Blank:** 0 to +70 degree C  
**H:** -10 to + 85 degree C  
**T:** -40 to + 85 degree C

## Appendix A. Document Revision

Version No.	Date	Description
0G	2006-11	Release
0H	2008-01	Update "Recommended Circuit Schematic", Correct SD Output Voltage 、 Pin Definition、 Package Outline、 Order Information